



ADSL Broadband

- how it works
- the local network
- the bigger picture
- the local picture

Ian Binks
0121 230 2950
ian.binks@bt.com



How does it work?

- ADSL Broadband is delivered over a standard BT telephone line
- Digital Subscriber Line (DSL) is a technology for bringing high-bandwidth information to homes and small businesses over ordinary telephone lines

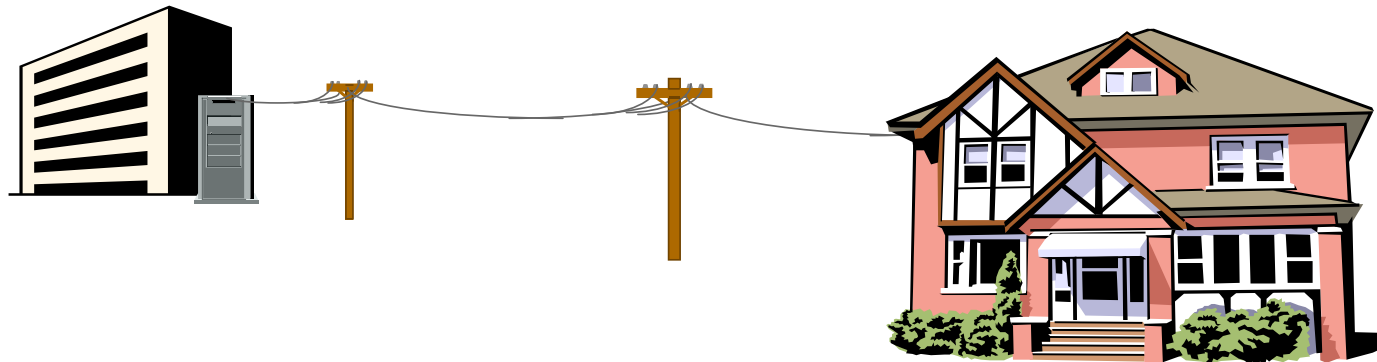

Voice & Data

- Web access & talk on the same line at the same time
 - Two services over the same copper pair
 - Two bills
 - Two types of fault process

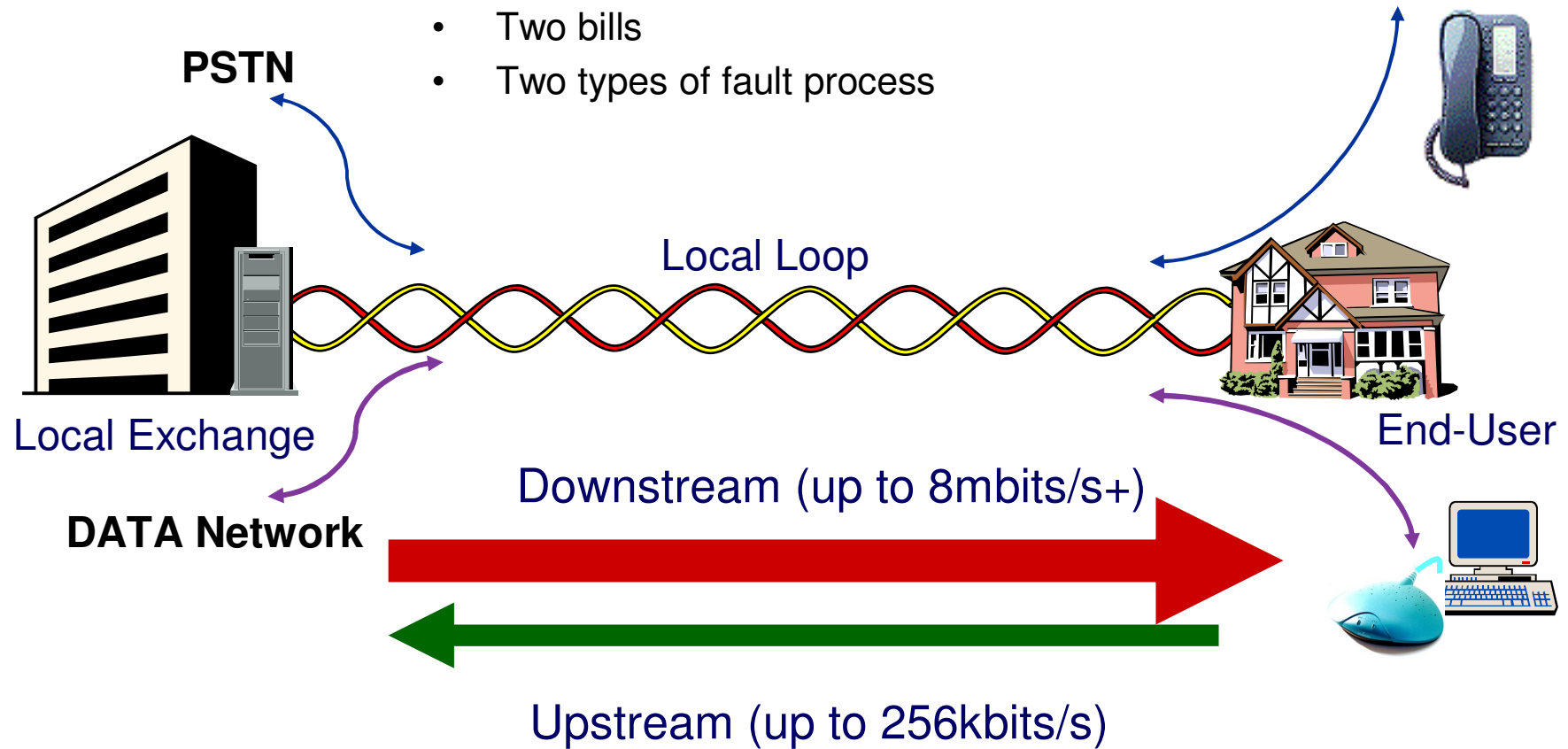

ADSL exchange connection

Main Distribution Frame

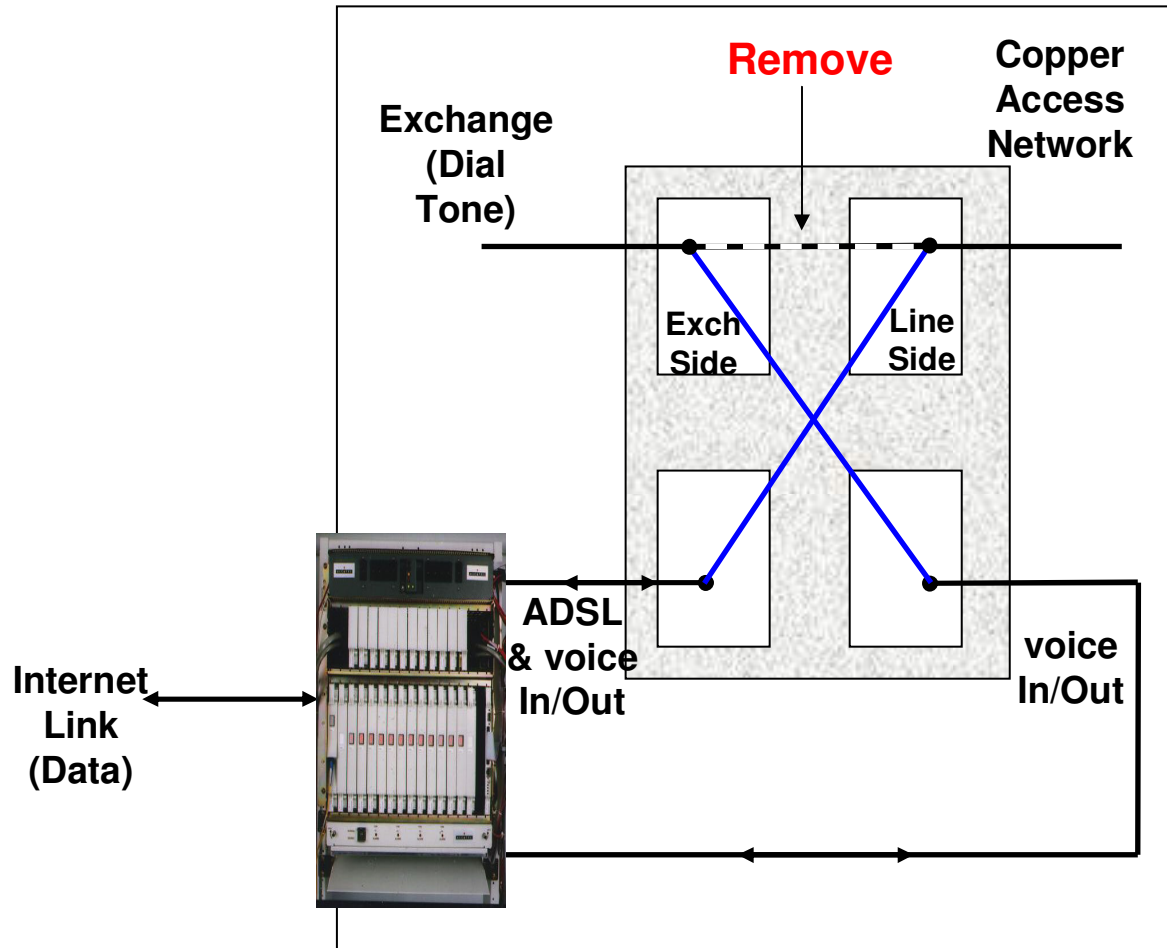

End-user splitters (filters)

- Two main types

**NTE2000
Service Specific Front Plate**

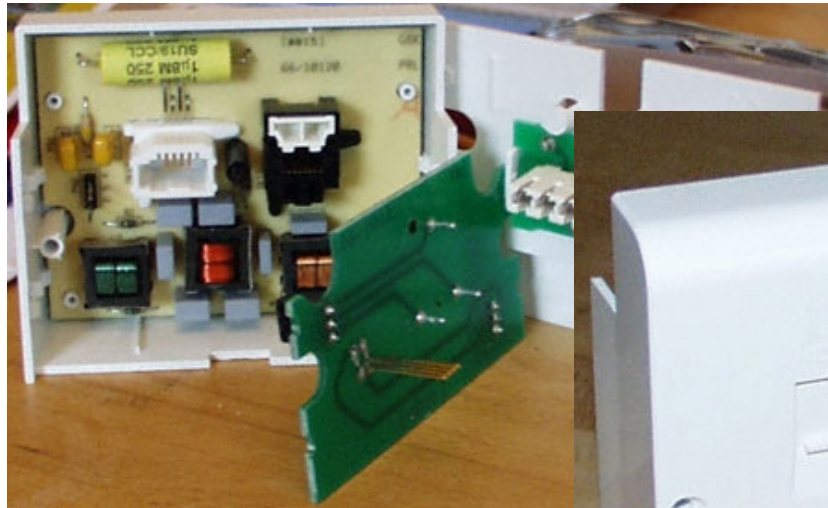

Micro Filter

Micro filters typically supplied by ISP

UK market structure

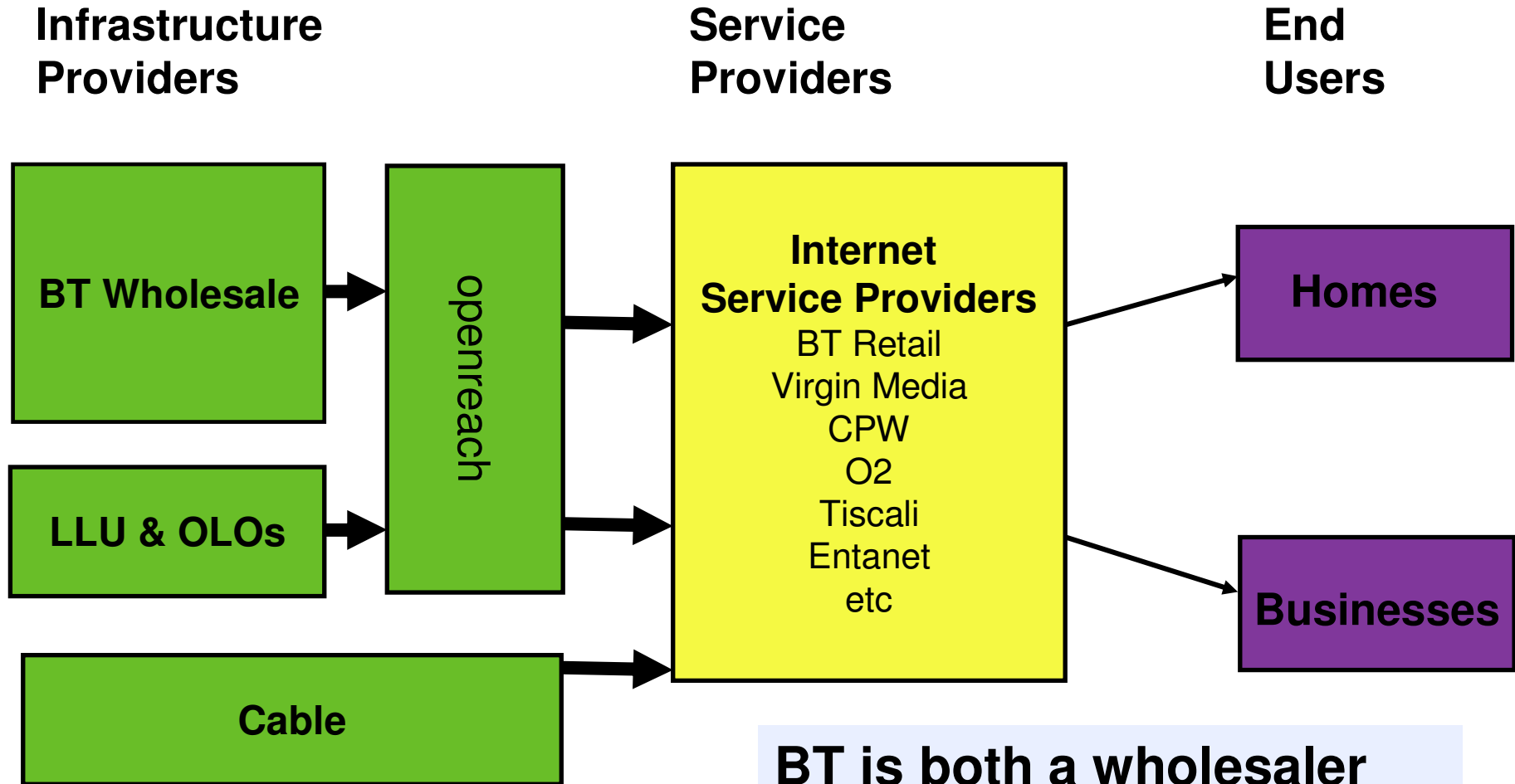

BT is both a wholesaler and a retailer

Internet access in the UK

BT DataStream with Customer Access Link

LLU = local loop unbundled

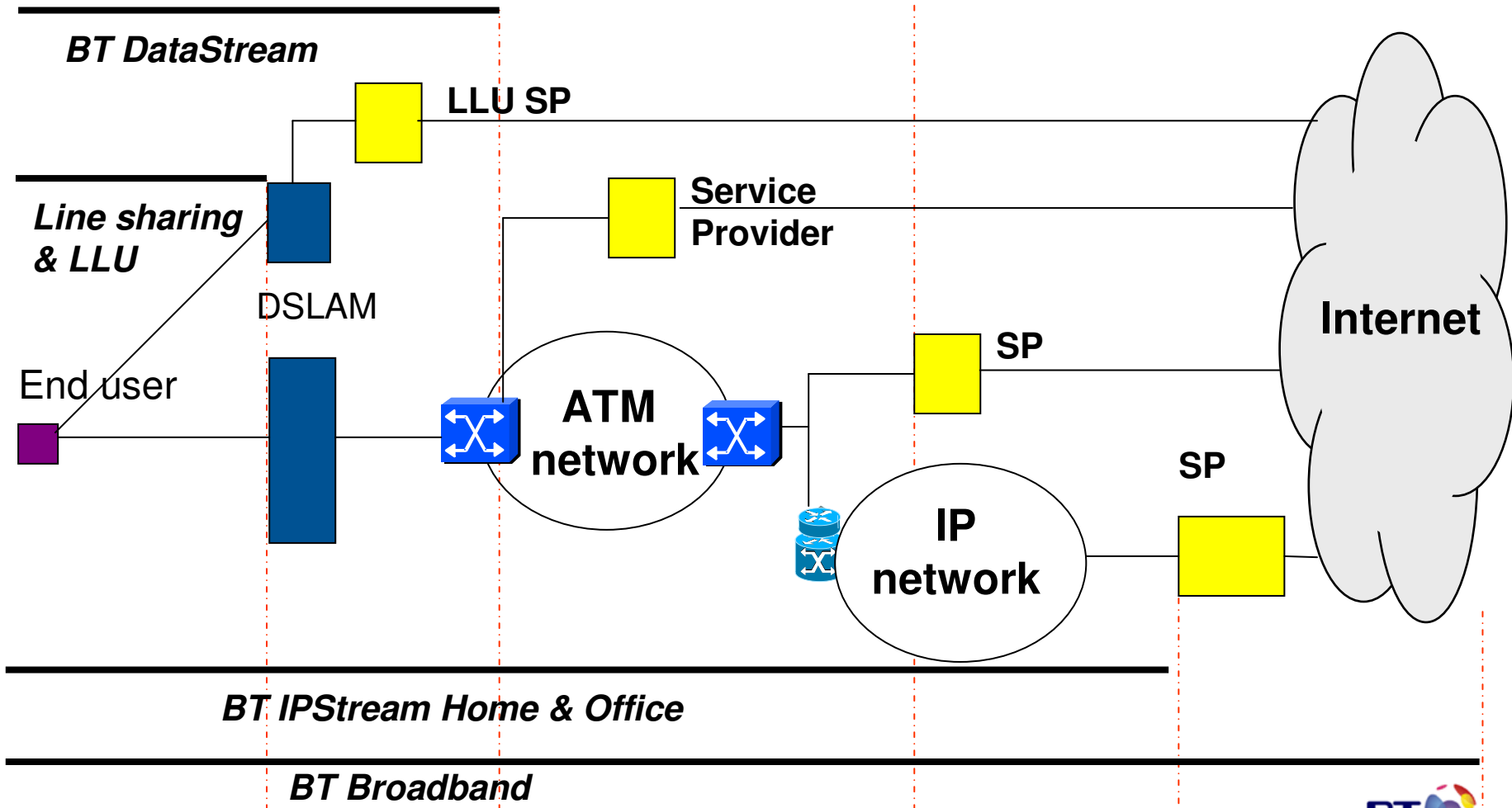

BT IPStream Home & Office

BT Broadband

DSL performance

- The performance of DSL on any given line in the access network is a function of the **signal to noise ratio** at the end of that line:
 - **Signal** is affected by the length, quality and dimensions of the copper (and sometime aluminium) cable,
 - **Noise** can come from
 - network crosstalk (directly related to the “fill” level of the cables in use,)
 - sources in the home or premises (including home wiring)
 - sources in the environment e.g. RFI from other electrical equipment
- Geographic coverage achieved at any given speed also depends on
 - the topology of the access network
 - the statistical distribution of line lengths

These factors are identical for anyone operating DSL on BT's access network

Points of Help

- Distance, an attempt will be made to provide service on every line unless a previous attempt failed, check on <http://eco.btwholesale.com/broadband1/>
- Customer wiring quality
 - <http://www.thinkbroadband.com/> Very useful site, lots of info
 - <http://www.Thinkbroadband.com/faq/sections/radsl.html#235> Good set of FAQs
 - <http://www.pcpro.co.uk/features/205881/double-your-broadband-for-free.html?searchString=double+your+speed> Specifically addresses speed issues
 - <http://www.thinkbroadband.com/files/broadband-max-myths-and-legends.pdf> this has a particularly useful section on how to repair home wiring
 - <http://www.thinkbroadband.com/news/3859-top-10-tips-on-how-to-improve-your-broadband-speeds.html>

iPlate

(<http://www.thinkbroadband.com/tools/phone-socket-identification.html>)



iPlate

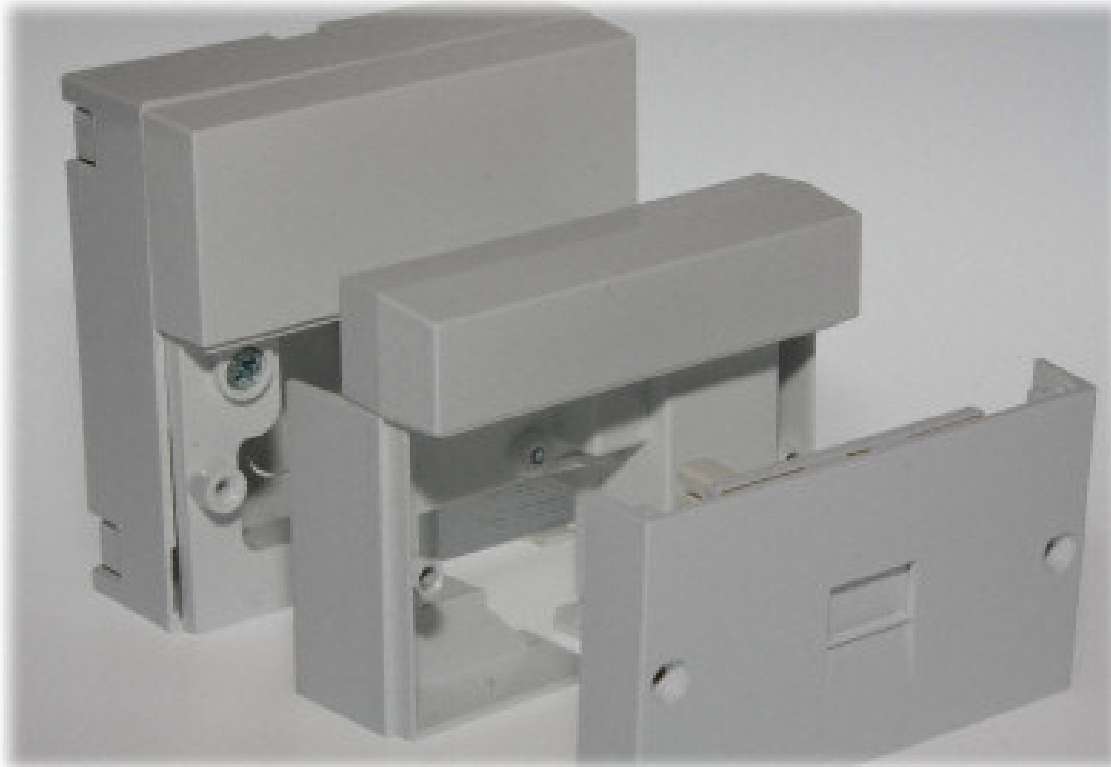

<http://www.dabs.com/>

Thank you